



6' Recycled Plastic Picnic Table with (2) Attached Seats - Portable.

- 260 lbs.
- Dim: 72"W x 60"D x 30"H - Top is 28"D.
- Table top and seats are made with 2" x 10" recycled plastic slats and 2" x 6" and 2" x 10" black recycled plastic frame.
- All holes are predrilled and countersunk for plastic lumber.
- Includes a UV protectant.
- Maintenance free.
- No umbrella hole.
- Table top and seats available in green, cedar, black, white and gray with black base.
- Mounting clamps available.
- Some assembly required.

Item #: JP PB6APIC

Resinwood Colors



White



Cedar



Green



Gray



Black

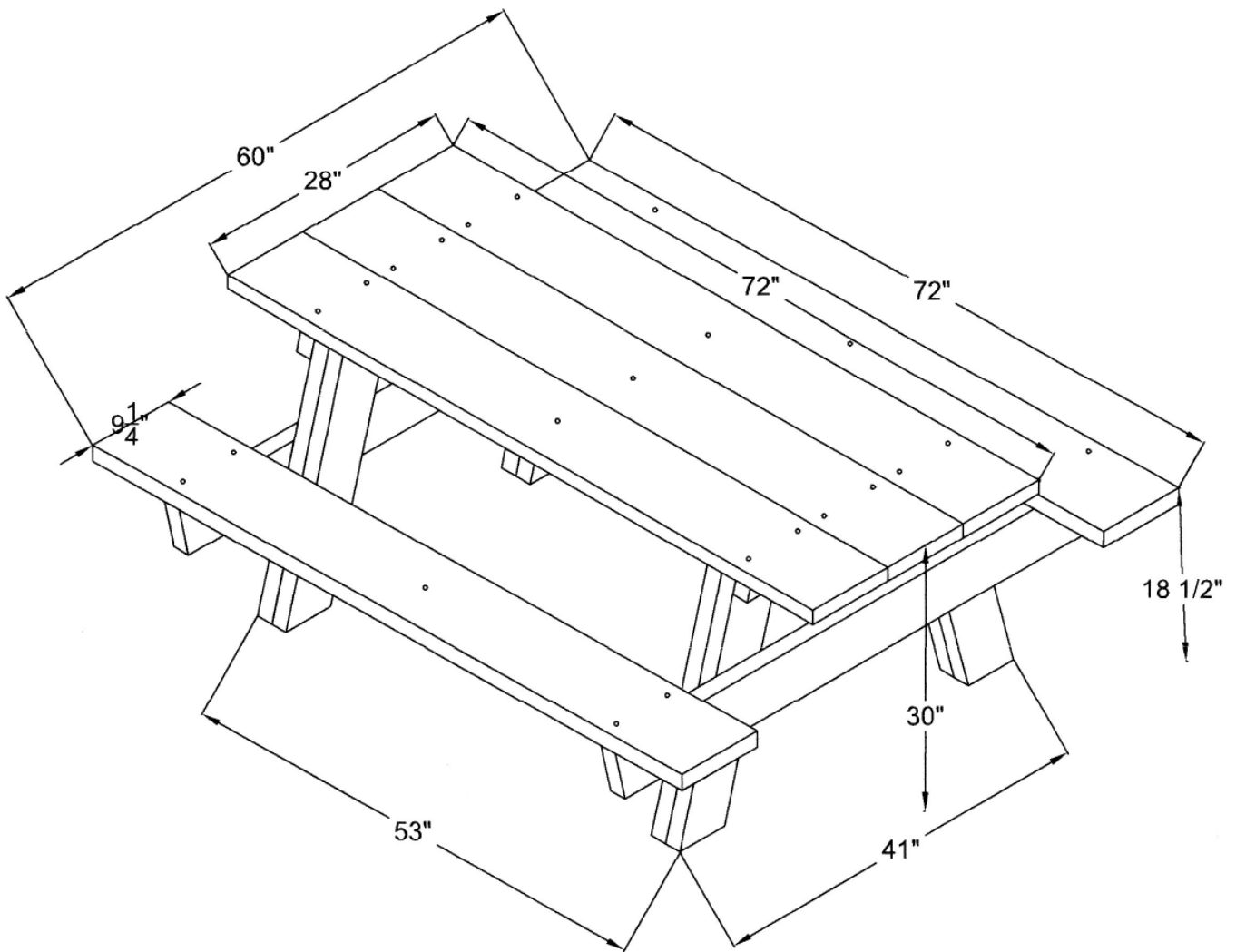

- TOP AND SEATS ARE RECYCLED PLASTIC
- BLACK RECYCLED PLASTIC BASE
- COMES WITH ZINC COATED HARDWARE
- STAINLESS STEEL HARDWARE AVAILABLE
- UNIT WEIGHT APPROX. 260LBS.

NATIONAL OUTDOOR FURNITURE, INC.

P.O. Box 296 Riverhead, NY 11901
 Toll-Free Phone: 1-888-663-4621
 Phone: 631-369-9099 Fax: 631-207-8312
 Email: nofinc@optonline.net
www.outdoorchaise.com

NATIONAL OUTDOOR FURNITURE, INC.

P.O. Box 325 Pomfret Center, Ct 06259
 Toll-Free Phone: 1-888-516-8873
 Phone: 1-860-974-9996 Fax: 516-706-1901
 Email: nofinc@earthlink.net
www.outdoorchaise.com