



**Hex Recycled Plastic Picnic Table with Attached Seats - Portable.**

- 250 lbs.
- Dim: 72" x72" Overall Width x 39"D Top.
- Made with 100% recycled plastic slats and black recycled plastic base.
- All holes are predrilled and countersunk for plastic lumber.
- Includes a UV protectant.
- Maintenance free.
- With umbrella hole.
- Available in green and cedar with black or green base.
- Some assembly required.
- Also available in ADA.

**Item #:** JP PB6HEX

**Resinwood Colors**



Black



Cedar



Green

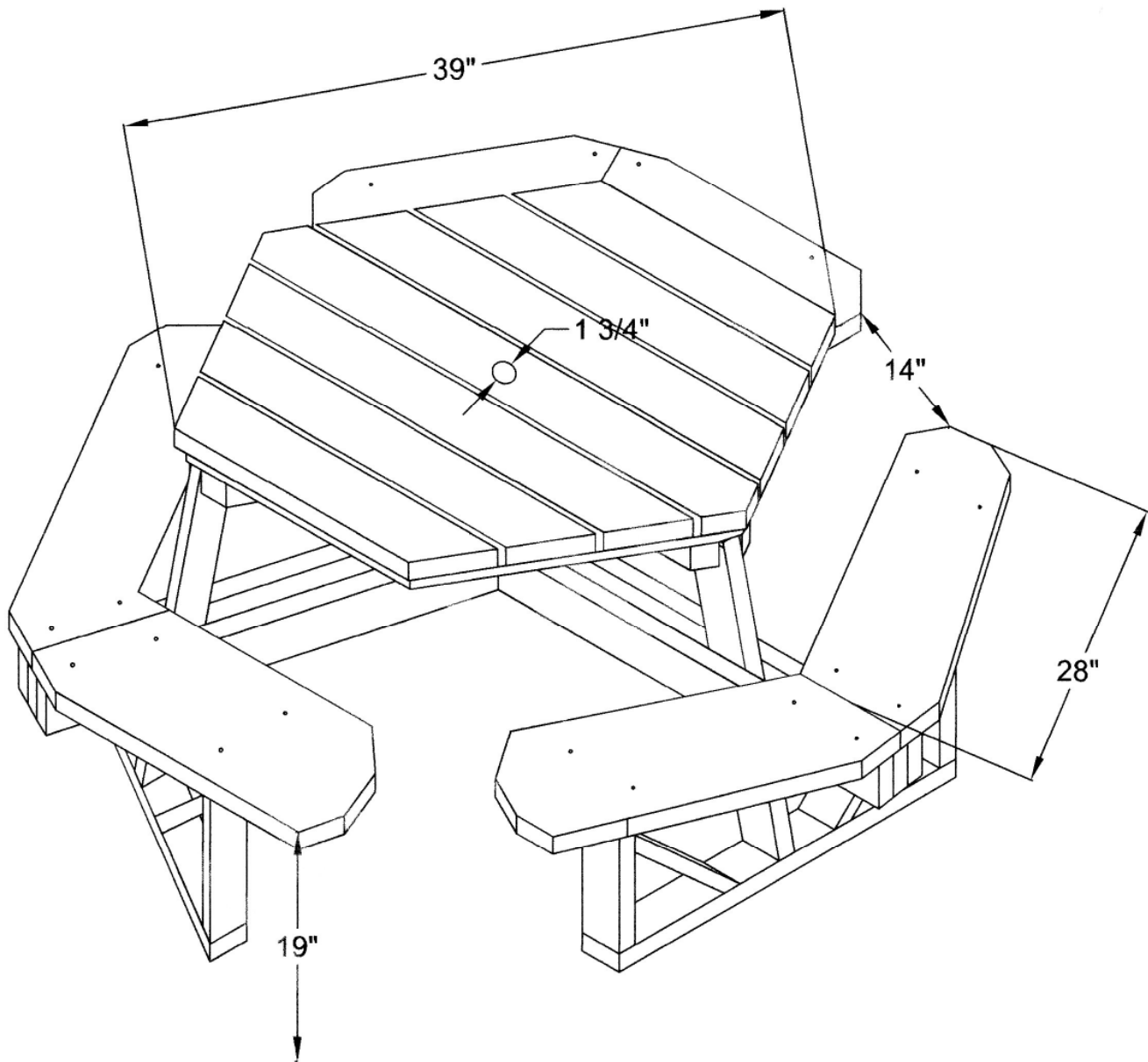

- SEAT, TABLE TOP AND BASE IS RECYCLED PLASTIC
- UMBRELLA HOLE IS STANDARD
- ALL HOLES PRE-DRILLED AND COUNTERSUNK
- COMES WITH HEAVY DUTY ZINC COATED HARDWARE
- STAINLESS STEEL HARDWARE AVAILABLE
- UNIT WEIGHT APPROX. 250 LBS.

**NATIONAL OUTDOOR FURNITURE, INC.**

P.O. Box 296 Riverhead, NY 11901  
 Toll-Free Phone: 1-888-663-4621  
 Phone: 631-369-9099 Fax: 631-207-8312  
 Email: [nofinc@optonline.net](mailto:nofinc@optonline.net)  
[www.outdoorchaise.com](http://www.outdoorchaise.com)

**NATIONAL OUTDOOR FURNITURE, INC.**

P.O. Box 325 Pomfret Center, Ct 06259  
 Toll-Free Phone: 1-888-516-8873  
 Phone: 1-860-974-9996 Fax: 516-706-1901  
 Email: [nofinc@earthlink.net](mailto:nofinc@earthlink.net)  
[www.outdoorchaise.com](http://www.outdoorchaise.com)