



**6' Lenexa Recycled Plastic Picnic Table with (2) Attached Seats - Portable.**

- 320 lbs.
- Dim: 72"W x 57 ¾"D x - Top is 28 ½"D.
- Made with nine 2" x 6" recycled plastic slats and black recycled plastic base.
- All holes are predrilled and countersunk for plastic lumber.
- Includes a UV protectant.
- Maintenance free.
- No umbrella hole.
- Available in green, cedar and gray, white with black base.
- Some assembly required.
- Also available in 6' ADA.

**Item #:** JP PB6LEN

**Resinwood Colors**



White



Cedar



Green



Gray



Black

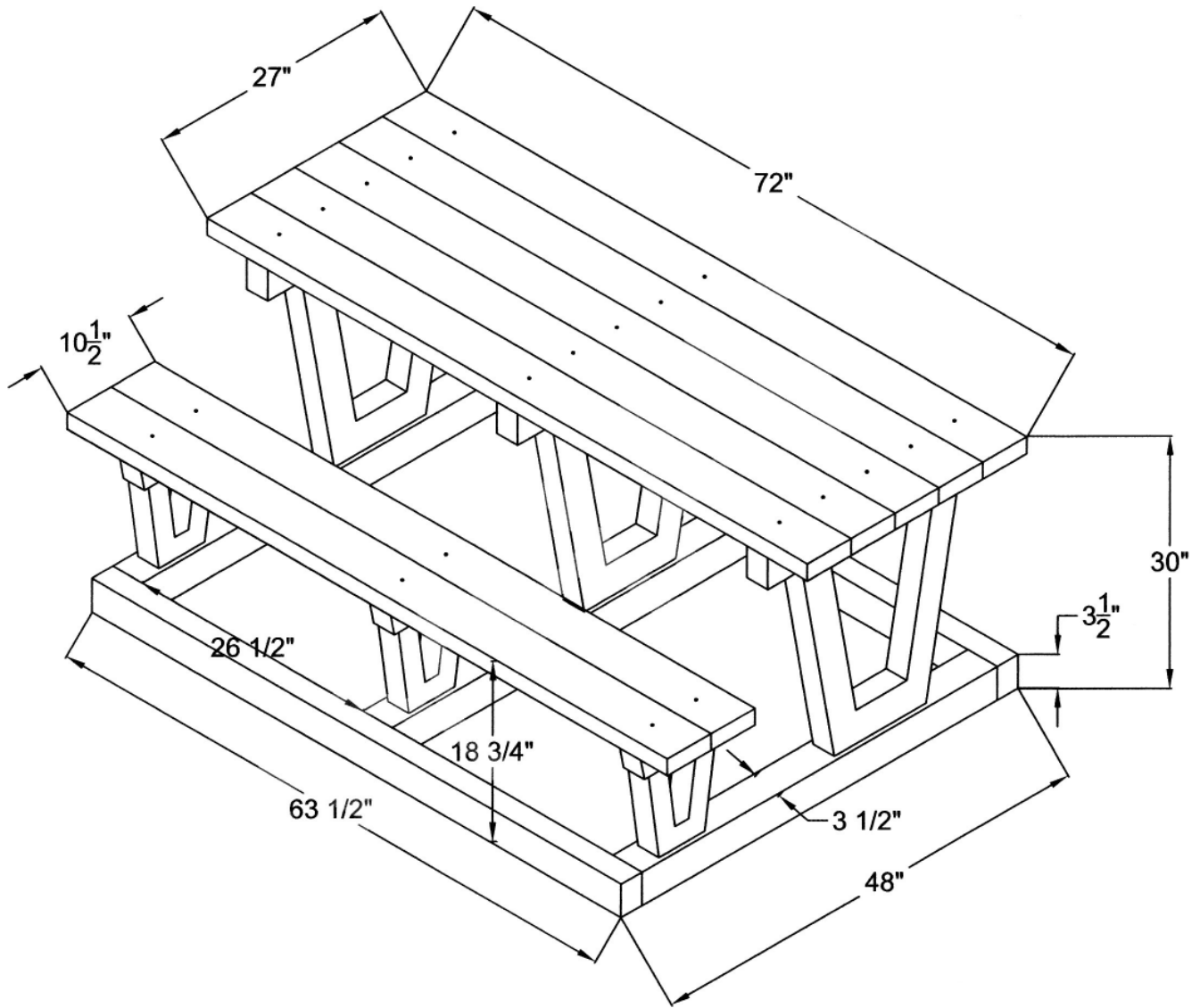

- TOP AND SEATS ARE 2"X6" RECYCLED PLASTIC
- BLACK RECYCLED PLASTIC BASE
- COMES WITH ZINC COATED HARDWARE
- UNIT WEIGHT APPROX. 290 LBS.

**NATIONAL OUTDOOR FURNITURE, INC.**

P.O. Box 296 Riverhead, NY 11901  
 Toll-Free Phone: 1-888-663-4621  
 Phone: 631-369-9099 Fax: 631-207-8312  
 Email: [nofinc@optonline.net](mailto:nofinc@optonline.net)  
[www.outdoorchaise.com](http://www.outdoorchaise.com)

**NATIONAL OUTDOOR FURNITURE, INC.**

P.O. Box 325 Pomfret Center, Ct 06259  
 Toll-Free Phone: 1-888-516-8873  
 Phone: 1-860-974-9996 Fax: 516-706-1901  
 Email: [nofinc@earthlink.net](mailto:nofinc@earthlink.net)  
[www.outdoorchaise.com](http://www.outdoorchaise.com)