



8' Recycled Plastic Picnic Table with (1) 6 Ft. Attached Seats, ADA - Portable.

- 435 lbs.
- Dim: 90"W x 57 ¾"D x - Top is 28 ½"D.
- Made with five 2" x 10" recycled plastic slats and black recycled plastic base.
- All holes are predrilled and countersunk for plastic lumber.
- Includes a UV protectant.
- Maintenance free.
- No umbrella hole.
- Table top and seats available in green, cedar, black, white and gray with black base.
- Some assembly required.

Item #: JP PB8PICADA

Resinwood Colors



White



Cedar



Green



Gray



Black

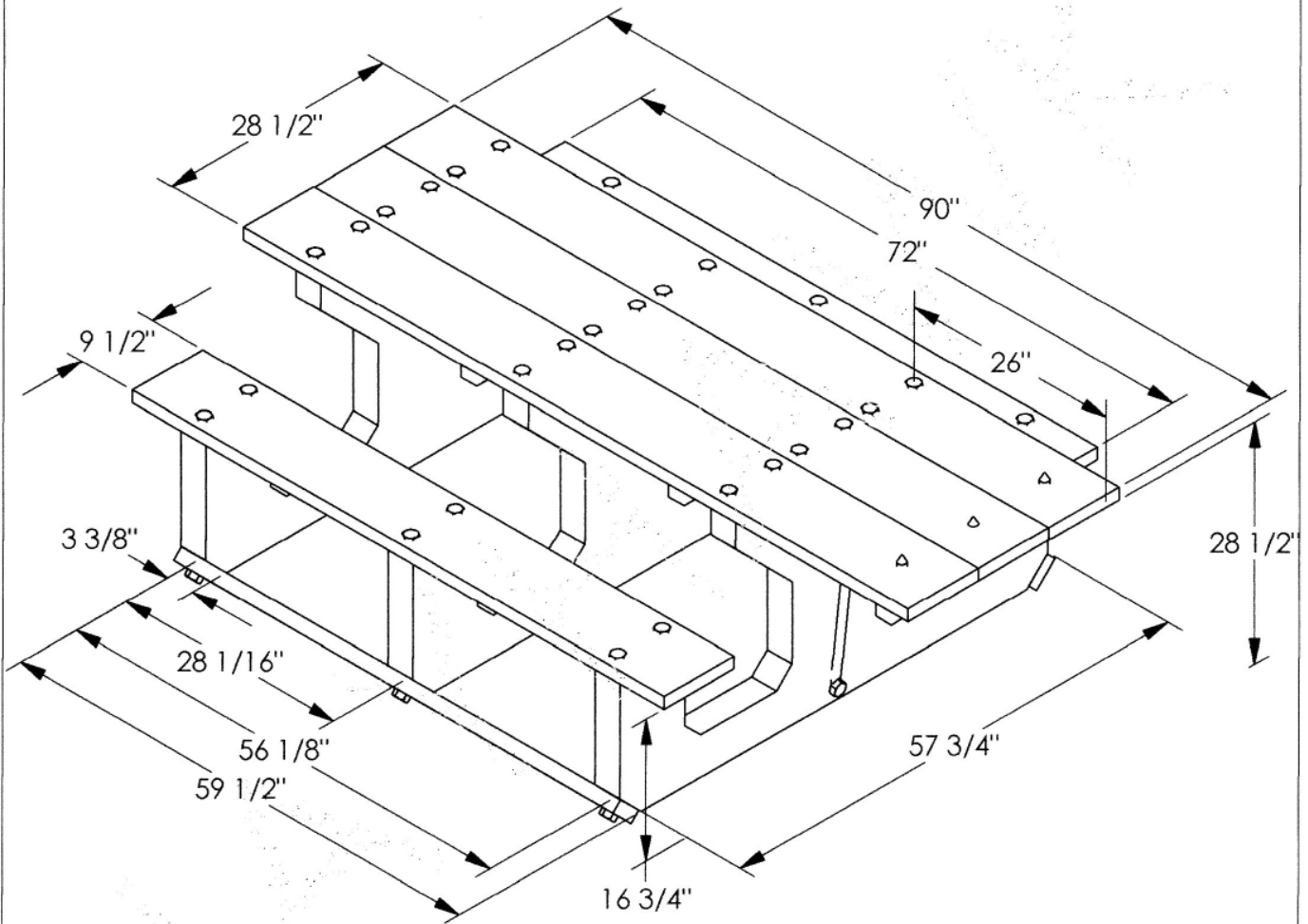

NOTES:

- 2 X 10 SLATS ARE RECYCLED PLASTIC
- BASES ARE RECYCLED PLASTIC
- ALL HOLES ARE PRE-DRILLED AND COUNTERSUNK FOR PLASTIC LUMBER
- BASES ARE HAND DRILLED IN FIELD
- ALL HARDWARE IS ZINC PLATED (1/2 X 4" LAG BOLT, 1/4 X 3 1/2" LAG SCREW, & 5/16 X 1 1/2" LAG SCREW)
- STAINLESS STEEL HARDWARE AVAILABLE
- UNIT WEIGHT APPROX. 435 LBS.

NATIONAL OUTDOOR FURNITURE, INC.

P.O. Box 296 Riverhead, NY 11901
 Toll-Free Phone: 1-888-663-4621
 Phone: 631-369-9099 Fax: 631-207-8312
 Email: nofinc@optonline.net
www.outdoorchaise.com

NATIONAL OUTDOOR FURNITURE, INC.

P.O. Box 325 Pomfret Center, Ct 06259
 Toll-Free Phone: 1-888-516-8873
 Phone: 1-860-974-9996 Fax: 516-706-1901
 Email: nofinc@earthlink.net
www.outdoorchaise.com