



31" Diameter Adjustable Fire Ring – Single Flange.

- 90 Lbs.
 - 300 Total square inch cooking surface.
 - Fire ring size: 31" diameter x 6" high.
- Available in 9" and 11 ¼" heights.
- Constructed with 3/16" thick steel (A569). Formed 1" flange for extra strength.
 - All joints continuously welded.
 - Fire ring tilts back 180 degrees for ease of fire building and clean out.
 - Four position adjustable theft proof grates are constructed from ½" dia. A36 Steel bars located on 1-1/8" centers. Grate adjusts from 7 ½"-14" above firebox .
 - Grate handles constructed from 5/8" dia. A36 steel bars and are equipped with stay cool spring grips..
 - Non-toxic black powder coat finish with staple anchors.
 - Available in additional sizes.
 - Some assembly required.

Item #: JTA FRA316



◀ Staples are included for permanent mounting. Staples allow the ring to tilt back for ease of maintenance

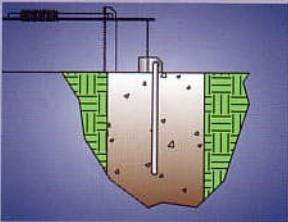

◀ Staple mount shown.

31" Diameter x 6" High

- Fire ring has an overall diameter of 32 5/8" x 6" high and is constructed of 3/16" thick steel (A569).
- Fire ring is constructed with a formed (not welded) 1" flange for superior strength.
- Grate is constructed from 1/2" dia. A36 steel bars located on 1 1/8" centers. The four position theft proof grate adjusts from 8 1/2" to 14" above the firebed, and has a cooking area of 265 sq. inches.
- Grate handles are constructed of a 5/8" dia. A36 steel bar with stay cool spring grips suitable for public use.
- Ring is mounted using staples that allow the ring to tilt back for ease of cleaning or optional spade anchors. The spade anchors permanently anchor the fire ring to the ground.
- All joints are continuously welded.
- All exposed corners are chamfered for safety.
- Standard finish is a non-toxic black powder coat.
- Approximate weight = 80 lbs.

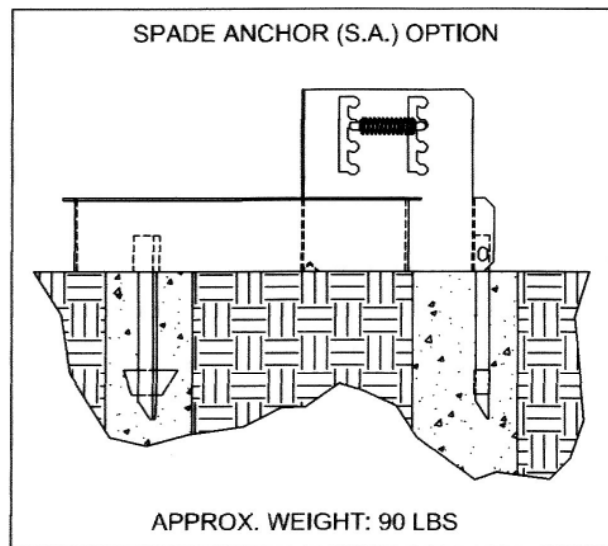
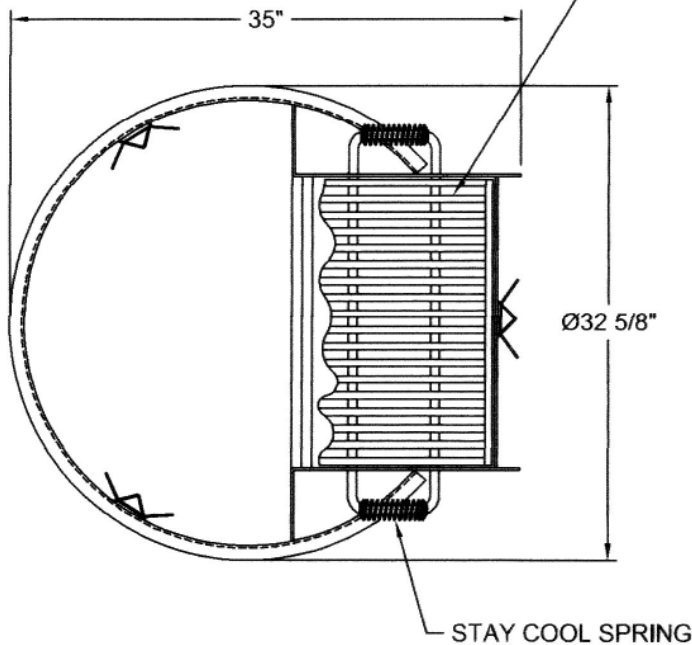
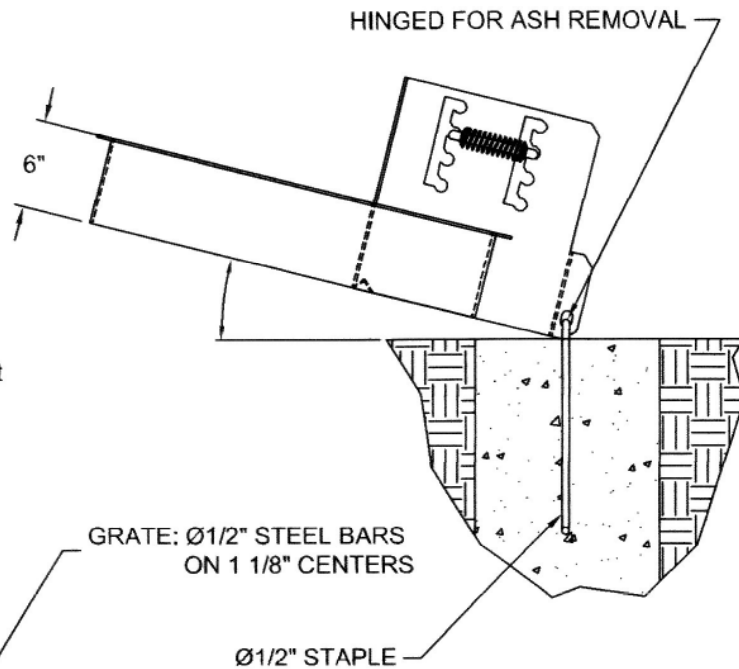

NOTE : CUSTOMER TO PROVIDE CONCRETE (RECOMMENDED)

NATIONAL OUTDOOR FURNITURE, INC.

P.O. Box 296 Riverhead, NY 11901
 Toll-Free Phone: 1-888-663-4621
 Phone: 631-369-9099 Fax: 631-207-8312
 Email: nofinc@optonline.net
www.outdoorchaise.com

NATIONAL OUTDOOR FURNITURE, INC.

P.O. Box 325 Pomfret Center, Ct 06259
 Toll-Free Phone: 1-888-516-8873
 Phone: 1-860-974-9996 Fax: 516-706-1901
 Email: nofinc@earthlink.net
www.outdoorchaise.com