



**Double Wall 32" Diameter Adjustable Fire Ring- ADA Compliant.**

- 242 Lbs.
- 300 Total square inch cooking surface with log grate.
- Fire ring size: 35 7/8" Diameter x 15 3/4" high with drain/draft holes.
- Constructed with 3/16" thick steel (A569).
- All joints continuously welded.
- Cooking grate tilts back 180 degrees for ease of fire building and clean out.
- Four position adjustable theft proof grates are constructed from 1/2" dia. A36 Steel bars located on 1-1/8" centers. Grates adjust 18 1/4"-23 3/4" above firebox.
- Grate handles constructed from 5/8" dia. A36 steel bars and are equipped with stay cool spring grips..
- Non-toxic black powder coat finish with staple anchors.
- Some assembly required.

**Item #:** JTA FRADHC



◀ Staples are included for permanent mounting. Staples allow the ring to tilt back for ease of maintenance

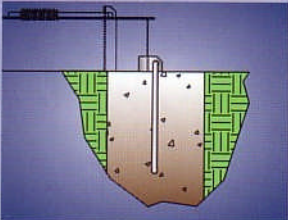

◀ Staple mount shown.

- Double wall fire ring has an overall diameter of 35 7/8" x 15 3/4" high complete with drain/draft holes, and is constructed of 3/16" thick steel (A1011).
- Grate is constructed from 1/2" dia. A36 steel bars located on 1 1/8" centers. The four position theft proof grate adjusts from 18 1/4" to 23 3/4" above the firebed, and has a cooking area of 300 sq. inches.
- Grate handles are constructed of a 5/8" dia. A36 steel bar with stay cool spring grips suitable for public use.
- Ring is mounted using staples that allow the ring to tilt back for ease of cleaning or optional spade anchors. The spade anchors permanently anchor the fire ring to the ground.
- All joints are continuously welded.
- All exposed corners are chamfered for safety.
- Standard finish is a non-toxic black powder coat.
- Approximate weight = 232 lbs.

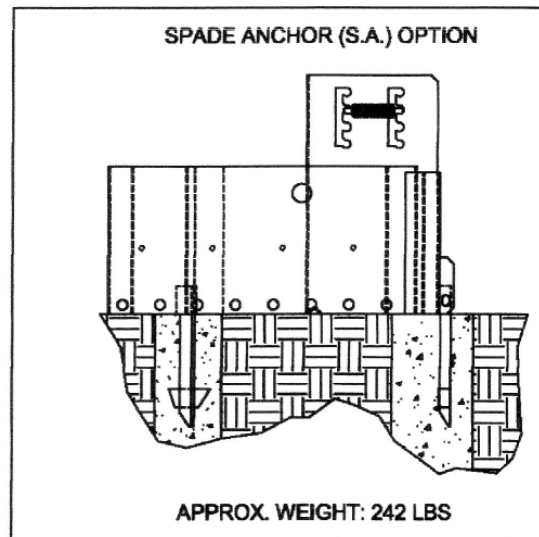
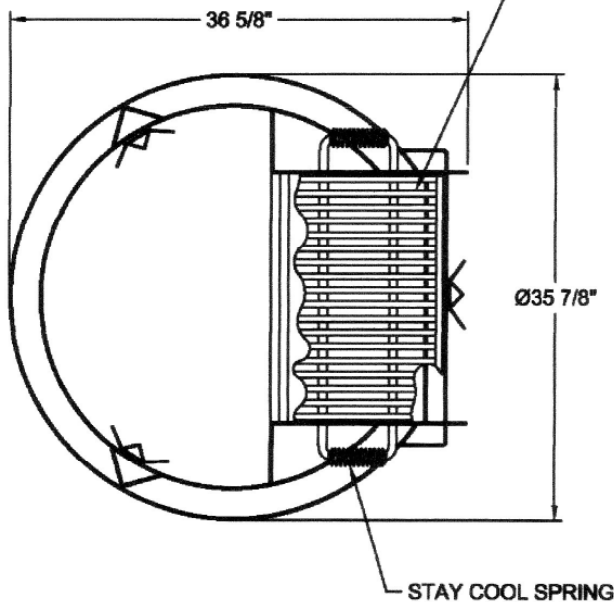
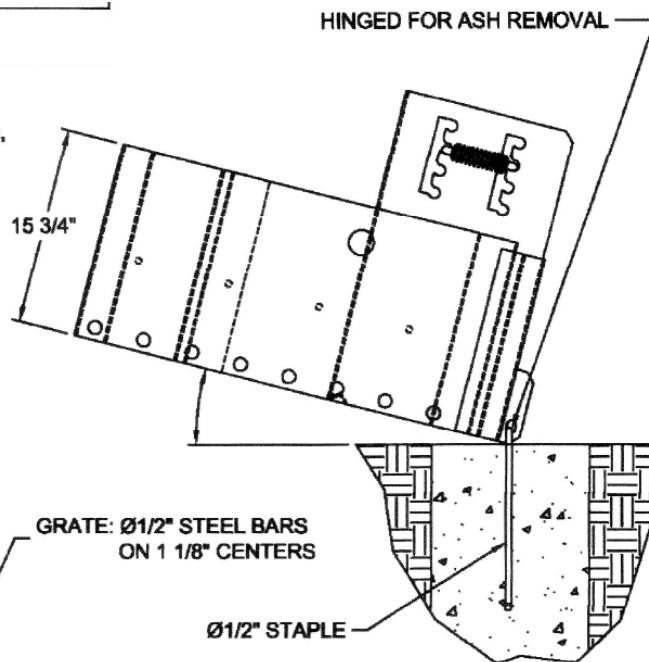

NOTE : CUSTOMER TO PROVIDE CONCRETE ( RECOMMENDED )

**NATIONAL OUTDOOR FURNITURE, INC.**

P.O. Box 296 Riverhead, NY 11901  
 Toll-Free Phone: 1-888-663-4621  
 Phone: 631-369-9099 Fax: 631-207-8312  
 Email: [nofinc@optonline.net](mailto:nofinc@optonline.net)  
[www.outdoorchaise.com](http://www.outdoorchaise.com)

**NATIONAL OUTDOOR FURNITURE, INC.**

P.O. Box 325 Pomfret Center, Ct 06259  
 Toll-Free Phone: 1-888-516-8873  
 Phone: 1-860-974-9996 Fax: 516-706-1901  
 Email: [nofinc@earthlink.net](mailto:nofinc@earthlink.net)  
[www.outdoorchaise.com](http://www.outdoorchaise.com)