

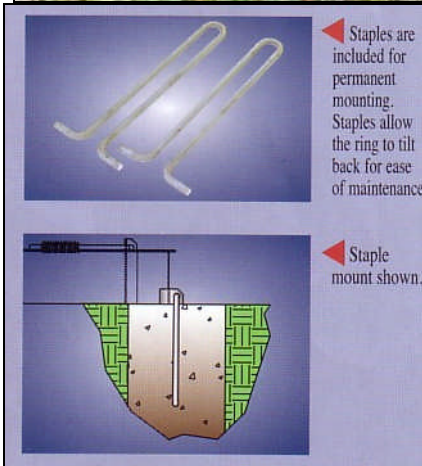

### 30" Diameter Non Adjustable Fire Ring-Double Flange.

- 72 Lbs.
  - 270 Total square inch cooking surface.
  - Fire ring size: 32 7/8" diameter x 7" high.
- Available in 9" and 11 1/4" heights.
- Constructed with 3/16" thick steel (A569). Formed double flange for extra strength.
  - All joints continuously welded.
  - Grate tilts back 180 degrees for ease of fire building and clean out.
  - Non adjustable theft proof grates are constructed from 1/2" dia. A36 Steel bars located on 1-1/8" centers..
  - Grate handles constructed from 5/8" dia. A36 steel bars and are equipped with stay cool spring grips..
  - Non-toxic black powder coat finish with staple anchors.
  - Available in additional sizes.
  - Some assembly required.

**Item #:** JTA FRN307D



## 30" Diameter x 7" High

- Fire ring has an overall diameter of 32 1/8" x 7" high and is constructed of 3/16" thick steel (A569).
- Fire ring is constructed with a formed (not welded) double flange for superior strength.
- Grate is constructed from 1/2" dia. A36 steel bars located on 1 1/8" centers. The non-adjustable theft proof grate has a cooking area of 270 sq. inches.
- Grate handle is constructed of a 5/8" dia. A36 steel bar with stay cool spring grips suitable for public use.
- Ring is mounted using staples that allow the ring to tilt back for ease of cleaning or optional spade anchors. The spade anchors permanently anchor the fire ring to the ground.
- All joints are continuously welded.
- All exposed corners are chamfered for safety.
- Standard finish is a non-toxic black powder coat.
- Approximate weight = 62 lbs.

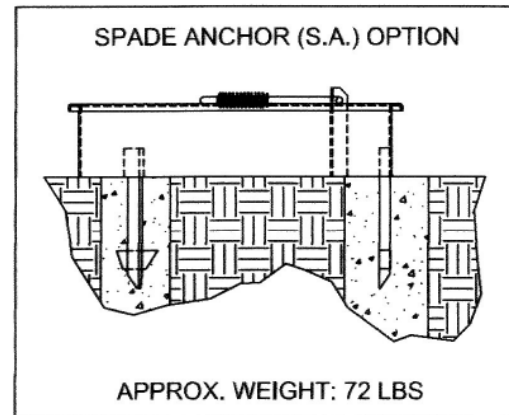
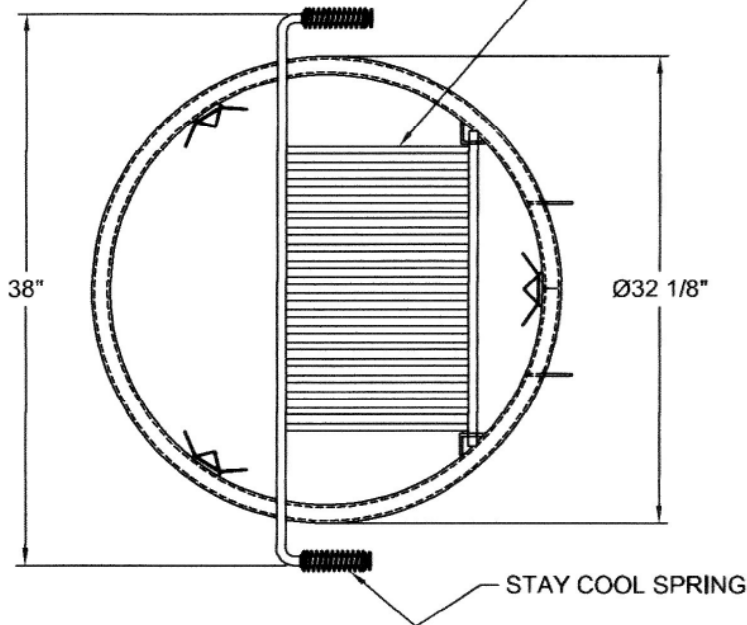
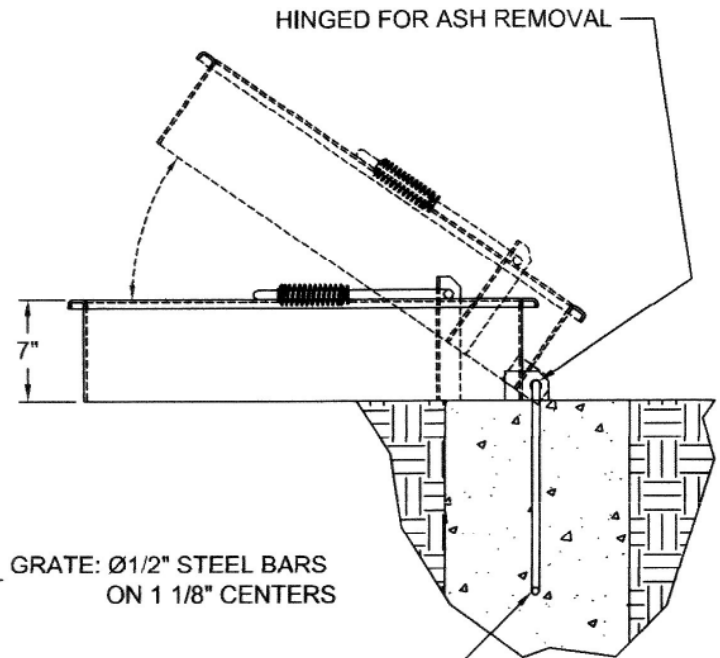

NOTE : CUSTOMER TO PROVIDE CONCRETE ( RECOMMENDED )

### NATIONAL OUTDOOR FURNITURE, INC.

P.O. Box 296 Riverhead, NY 11901  
 Toll-Free Phone: 1-888-663-4621  
 Phone: 631-369-9099 Fax: 631-207-8312  
 Email: [nofinc@optonline.net](mailto:nofinc@optonline.net)  
[www.outdoorchaise.com](http://www.outdoorchaise.com)

### NATIONAL OUTDOOR FURNITURE, INC.

P.O. Box 325 Pomfret Center, Ct 06259  
 Toll-Free Phone: 1-888-516-8873  
 Phone: 1-860-974-9996 Fax: 516-706-1901  
 Email: [nofinc@earthlink.net](mailto:nofinc@earthlink.net)  
[www.outdoorchaise.com](http://www.outdoorchaise.com)